

Communicative rotary actuator fail-safe for adjusting dampers with safety function in technical building installations

- Air damper size up to approx. 0.5 m<sup>2</sup>
- Torque motor 2.5 Nm
- Nominal voltage AC/DC 24 V
- Control modulating, communicative 2...10 V variable
- Position feedback 2...10 V variable
- Communication via Belimo MP-Bus
- Conversion of sensor signals



## Technical data

<b>Electrical data</b>	Nominal voltage	AC/DC 24 V
	Nominal voltage frequency	50/60 Hz
	Nominal voltage range	AC 19.2...28.8 V / DC 21.6...28.8 V
	Power consumption in operation	2.5 W
	Power consumption in rest position	1 W
	Power consumption for wire sizing	4 VA
	Connection supply / control	Cable 1 m, 4x 0.75 mm <sup>2</sup>
	Parallel operation	Yes (note the performance data)
<b>Data bus communication</b>	Communicative control	MP-Bus
	Number of nodes	MP-Bus max. 8
<b>Functional data</b>	Torque motor	2.5 Nm
	Torque fail-safe	2.5 Nm
	Operating range Y	2...10 V
	Input impedance	100 kΩ
	Operating range Y variable	Start point 0.5...30 V End point 2.5...32 V
	Operating modes optional	Open/close
	Position feedback U	2...10 V
	Position feedback U note	Max. 0.5 mA
	Position feedback U variable	Start point 0.5...8 V End point 2.5...10 V
	Position accuracy	±5%
	Direction of motion motor	selectable with switch L/R
	Direction of motion note	Y = 0 V: At switch position 0 (ccw rotation) / 1 (cw rotation)
	Direction of motion variable	electronically reversible
	Direction of motion fail-safe	selectable by mounting L/R
	Manual override	No
	Angle of rotation	Max. 95°
	Angle of rotation note	adjustable starting at 37% in 2.5% steps (with mechanical end stop)
Running time motor	150 s / 90°	
Running time fail-safe	<25 s / 90°	
Adaptation setting range	manual	

**Technical data**

<b>Functional data</b>	Adaptation setting range variable	No action Adaptation when switched on Adaptation after using the rotation switch	
	Override control	MAX (maximum position) = 100% MIN (minimum position) = 0% ZS (intermediate position, AC only) = 50%	
	Override control variable	MAX = (MIN + 32%)...100% MIN = 0%...(MAX - 32%) ZS = MIN...MAX	
	Sound power level, motor	50 dB(A)	
	Mechanical interface	Universal shaft clamp 6...12.7 mm	
	Position indication	Mechanical	
	Service life	Min. 60'000 fail-safe positions	
	<b>Safety data</b>	Protection class IEC/EN	III, Safety Extra-Low Voltage (SELV)
		Degree of protection IEC/EN	IP42
EMC		CE according to 2014/30/EU	
Certification IEC/EN		IEC/EN 60730-1 and IEC/EN 60730-2-14	
Hygiene test		According to VDI 6022 Part 1 / SWKI VA 104-01, cleanable and disinfected, low emission	
Type of action		Type 1	
Rated impulse voltage supply / control		0.8 kV	
Pollution degree		3	
Ambient humidity		Max. 95% RH, non-condensing	
Ambient temperature		-30...50°C [-22...122°F]	
Storage temperature		-40...80°C [-40...176°F]	
Servicing		maintenance-free	
<b>Weight</b>		Weight	0.68 kg

**Safety notes**

- This device has been designed for use in stationary heating, ventilation and air-conditioning systems and must not be used outside the specified field of application, especially in aircraft or in any other airborne means of transport.
- Outdoor application: only possible in case that no (sea) water, snow, ice, insolation or aggressive gases interfere directly with the device and that it is ensured that the ambient conditions remain within the thresholds according to the data sheet at any time.
- Only authorised specialists may carry out installation. All applicable legal or institutional installation regulations must be complied with during installation.
- The device may only be opened at the manufacturer's site. It does not contain any parts that can be replaced or repaired by the user.
- Cables must not be removed from the device.
- The device contains electrical and electronic components and must not be disposed of as household refuse. All locally valid regulations and requirements must be observed.

Product features

- Operating mode** The actuator moves the damper to the operating position at the same time as tensioning the return spring. The damper is turned back to the fail-safe position by spring force when the supply voltage is interrupted.  
 Conventional operation:  
 The actuator is connected with a standard control signal of 0...10 V and drives to the position defined by the control signal. Measuring voltage U serves for the electrical display of the damper position 0...100% and as control signal for other actuators.  
 Operation on Bus:  
 The actuator receives its digital control signal from the higher level controller via the MP-Bus and drives to the position defined. Connection U serves as communication interface and does not supply an analogue measuring voltage.
- Converter for sensors** Connection option for a sensor (active sensor or switching contact). The MFT actuator serves as an analogue/digital converter for the transmission of the sensor signal via MP-Bus to the higher level system.
- Parametrisable actuators** The factory settings cover the most common applications. Single parameters can be modified with the Belimo service tools MFT-P or ZTH EU.
- Simple direct mounting** Simple direct mounting on the damper shaft with a universal shaft clamp, supplied with an anti-rotation device to prevent the actuator from rotating.
- Adjustable angle of rotation** Adjustable angle of rotation with mechanical end stops.
- High functional reliability** The actuator is overload protected, requires no limit switches and automatically stops when the end stop is reached.
- Home position** The first time the supply voltage is switched on, i.e. at the time of commissioning, the actuator carries out a synchronisation. The synchronisation is in the home position (0%).  
 The actuator then moves into the position defined by the control signal.

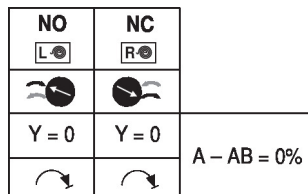

- Adaptation and synchronisation** An adaptation can be triggered manually by switching the direction of rotation switch from the left to the right twice within 5s or with the PC-Tool. Both mechanical end stops are detected during the adaptation (entire setting range). Automatic synchronisation after actuating the direction of rotation switch once is programmed. The synchronisation is in the home position (0%).  
 The actuator then moves into the position defined by the control signal.  
 A range of settings can be adapted using the PC-Tool (see MFT-P documentation)

Accessories

Gateways	Description	Type
	Gateway MP to BACnet MS/TP	UK24BAC
	Gateway MP to Modbus RTU	UK24MOD
Electrical accessories	Description	Type
	Signal converter voltage/current 100 kΩ 4...20 mA, Supply AC/DC 24 V	Z-UIC
	Positioner for wall mounting	SGA24
	Positioner for built-in mounting	SGE24
	Positioner for front-panel mounting	SGF24
	Positioner for wall mounting	CRP24-B1

**Accessories**

Mechanical accessories	Description	Type
	Actuator arm	AH-TF
	Shaft extension 170 mm $\varnothing$ 10 mm for damper shaft $\varnothing$ 6...16 mm	AV6-20
	Ball joint suitable for damper crank arm KH8 / KH10	KG10A
	Ball joint suitable for damper crank arm KH8	KG8
	Damper crank arm Slot width 8.2 mm, clamping range $\varnothing$ 10...18 mm	KH8
	Screw fastening kit	SB-TF
	Angle of rotation limiter, with end stop	ZDB-TF
	Form fit adapter 8x8 mm	ZF8-TF
	Mounting kit for linkage operation for flat and side installation	ZG-TF1
	Anti-rotation mechanism 180 mm, Multipack 20 pcs.	Z-ARS180
Tools	Description	Type
	Service tool, with ZIP-USB function, for parametrisable and communicative Belimo actuators, VAV controller and HVAC performance devices	ZTH EU
	Belimo PC-Tool, Software for adjustments and diagnostics	MFT-P
	Adapter for Service-Tool ZTH	MFT-C

**Electrical installation**

**Supply from isolating transformer.**

Parallel connection of other actuators possible. Observe the performance data.

**Wire colours:**

- 1 = black
- 2 = red
- 3 = white
- 5 = orange

**Wiring diagrams**

MP-Bus

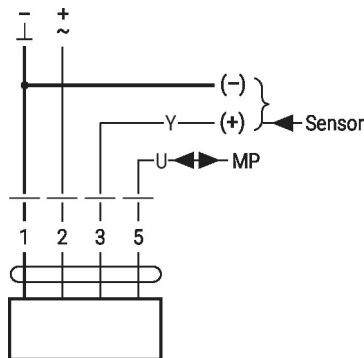

AC/DC 24 V, modulating

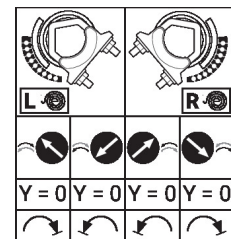
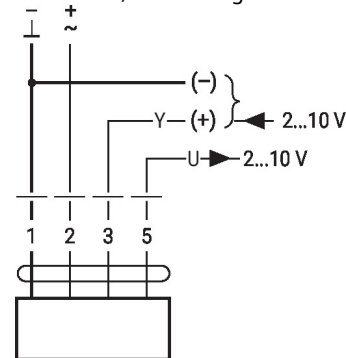

**Functions**

**Functions with basic values (conventional mode)**

Override control with AC 24 V with relay contacts

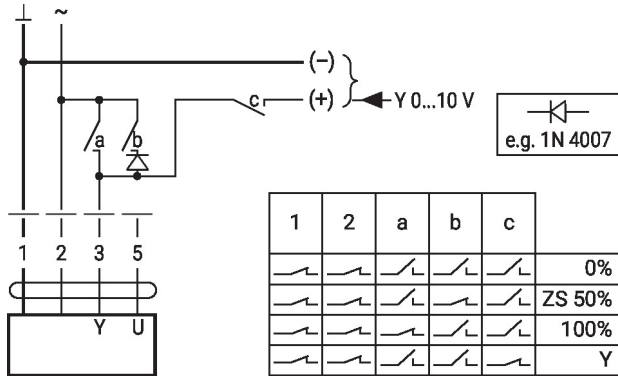

Minimum limit with positioner SG..

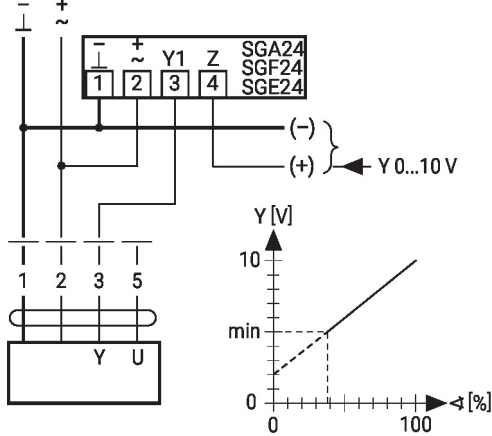

Control with 4...20 mA via external resistor

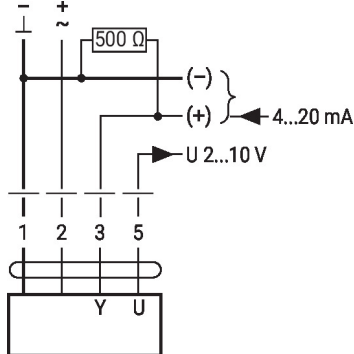

Override control with AC 24 V with rotary switch

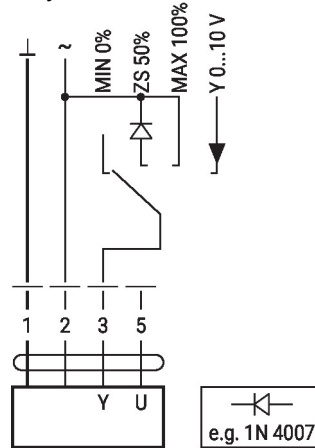

Control remotely 0...100% with positioner SG..

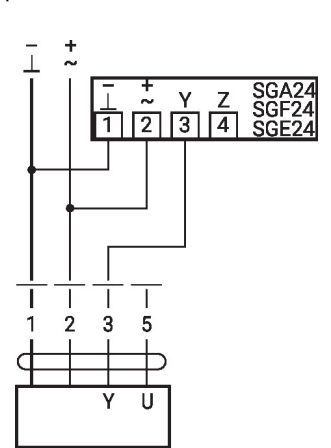

Primary/secondary operation (position-dependent)

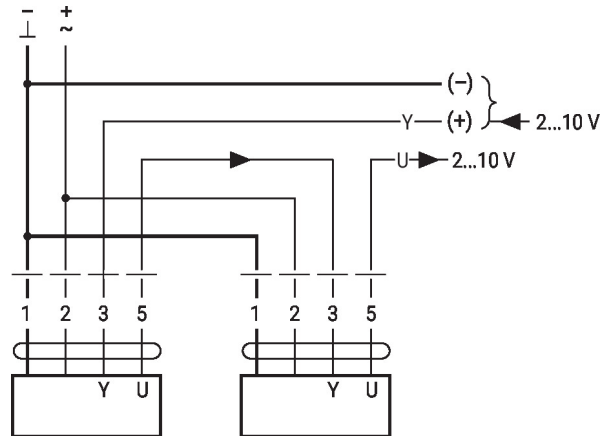

**Caution:**

The operating range must be set to DC 2...10 V.

The 500 Ohm resistor converts the 4...20 mA current signal to a voltage signal DC 2...10 V.

**Functions with basic values (conventional mode)**

Functional check

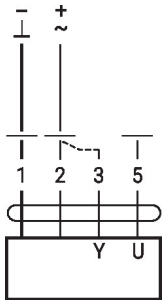
**Procedure**

1. Connect 24 V to connections 1 and 2
2. Disconnect connection 3:
  - With direction of rotation 0: Actuator rotates to the left
  - With direction of rotation 1: Actuator rotates to the right
3. Short-circuit connections 2 and 3:
  - Actuator runs in opposite direction

**Functions with specific parameters (Parametrisation necessary)**

Connection on the MP-Bus

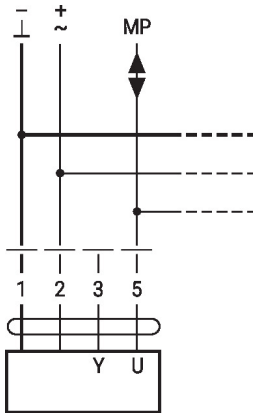

Max. 8 MP-Bus nodes

MP-Bus Network topology

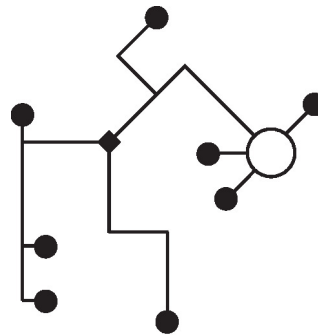

There are no restrictions for the network topology (star, ring, tree or mixed forms are permitted).  
Supply and communication in one and the same 3-wire cable

- no shielding or twisting necessary
- no terminating resistors required

Connection of active sensors

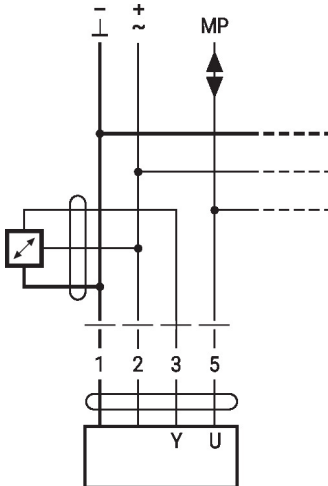

- Supply AC/DC 24 V
- Output signal 0...10 V (max. 0...32 V)
- Resolution 30 mV

Connection of external switching contact

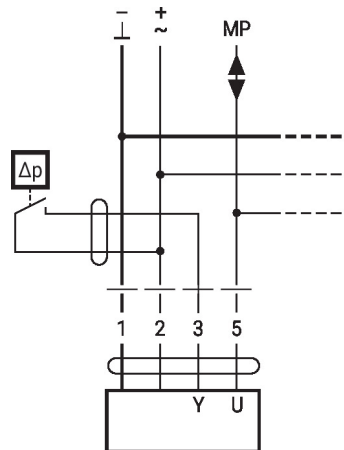

- Switching current 16 mA @ 24 V
- Start point of the operating range must be parametrised on the MP actuator as  $\geq 0.5$  V

**Functions**

**Functions with specific parameters (Parametrisation necessary)**

Override control and limiting with AC 24 V with relay contacts

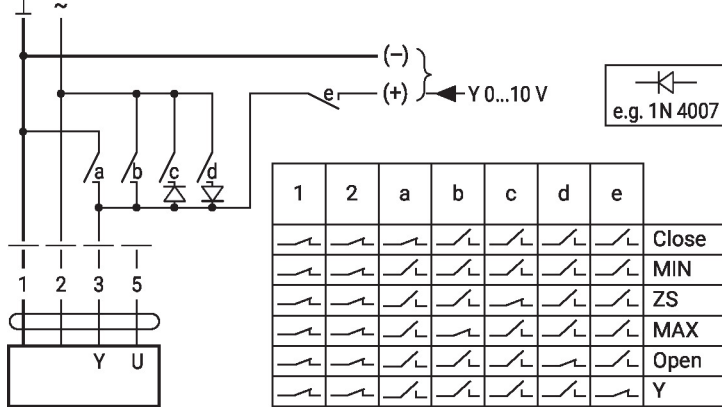

Control open/close

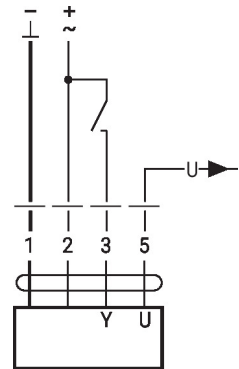

Override control and limiting with AC 24 V with rotary switch

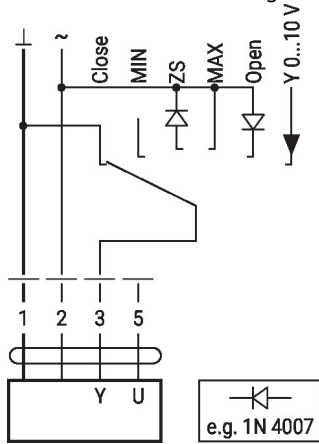

Control 3-point with AC 24 V

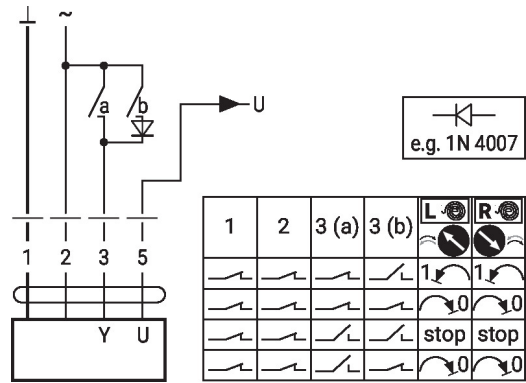

**Caution:**  
The "Close" function is only guaranteed if the start point of the operating range is defined as min. 0.5 V.

**Operating controls and indicators**

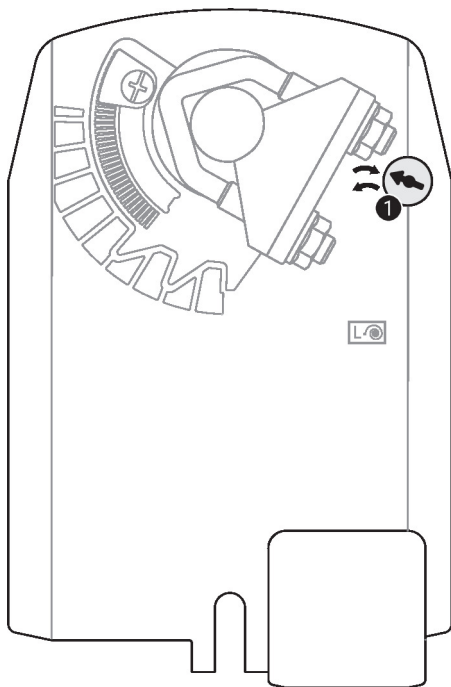

- 1 **MP addressing**  
Move direction of rotation switch in opposite position and backwards (within 4 seconds)

Service

**Tool connection** The actuator can be parametrised by ZTH EU via terminal connection. For extended parametrisation the PC tool can be connected.

Connection ZTH EU / PC-Tool

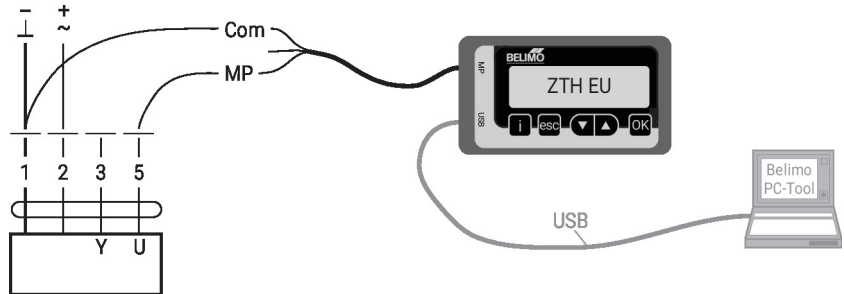

Dimensions

Spindle length

		Min. 84
		Min. 20

Clamping range

6...12.7	6...12.7

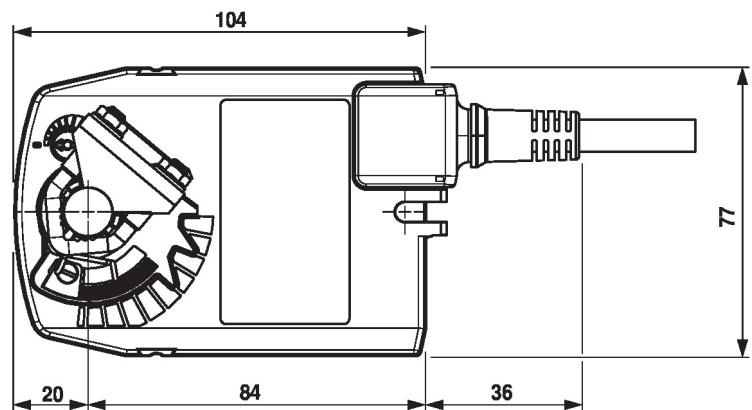
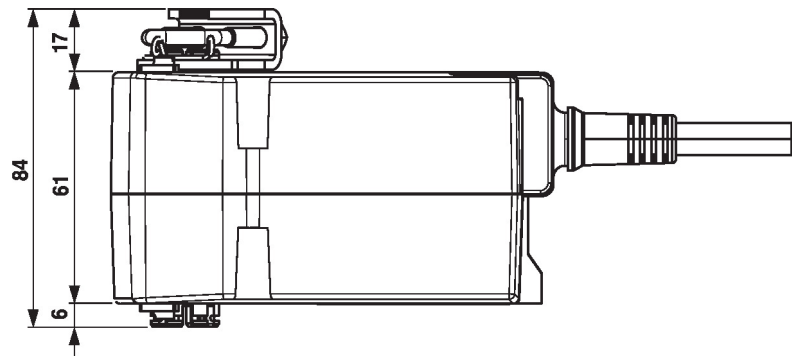

Further documentation

- Overview MP Cooperation Partners
- Tool connections
- Introduction to MP-Bus Technology

Application notes

- For digital control of actuators in VAV applications patent EP 3163399 must be considered.